

PCB terminal block — TL series (Raising Clamp)— TL217V/

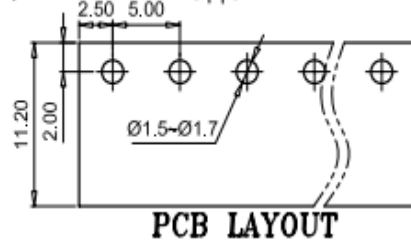
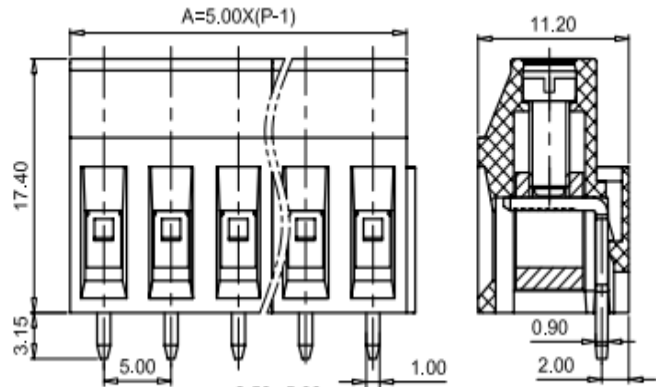

■ 图示(Pic. shown) : TL217VA-05P-G12S

General:	PCB terminal block	Rated : 320V,24A , 4.0mm ²
	Single row , 5.00mm pitch , 02-24 Pole	
	Wiring orientation: 180°(wire-to-board)	
	Screw clamp unit: M2.5, 0.5Nm Max	

认证 (Approval) :

技术参数 Technical Data	UL standard			IEC standard		
UL应用组别(UL Application group)	UL Application group			IEC过电压别/污染等级(IEC overvoltage category /pollution degree)		
IEC过电压别/污染等级(IEC overvoltage category /pollution degree)	B	C	D	III / 3	III / 2	II / 2
额定电压(Rated voltage)	300V	--	300V	--	320V	--
额定电流(Rated current)	20A	--	10A	--	24A	--
额定连接容量(Rated connection capacity)	24-12AWG Sol&Str			0.34-4.0mm ²		
绝缘材料(Insulation Material)	PA66 UL94 V-0					
电流承载部件材料和镀层(Material & Plating of Current carrier)	Copper alloy , Tin plated					
接线弹片材料(Material of Clamp spring)	--					
绝缘电阻(Insulation Resistance)	500MΩ or more at DC500V					
耐电压(1分钟)(Withstanding Voltage/1Min)	2200V					
额定冲击电压(Rated surge voltage)	--					
接线螺丝(Wire clamp unit Screw) , 最大扭矩(torque Max.)	M2.5 , 0.5Nm Max					
固定螺丝(Mounting Screw) , 扭矩(torque)	--					
剥线长度(Wire stripping length)	7.4mm					
使用温度(Operating temperature)	-40°C up to +105°C					
焊接方式(Soldering recommend)	Wave soldering ,260°C 5S Max (Single Wave) , 260°C 10S Max(Double Wave)					

■ 订购方式(How to order)

