

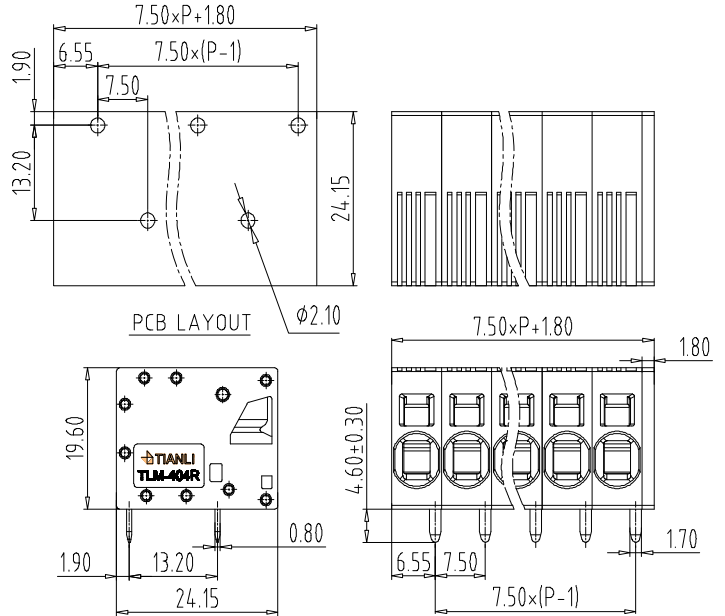

PCB terminal block — TLM series ( Screwless Type ) — TLM-404RA



■ 图示(Pic. shown) : TLM-404RA-04P-G12

|          |  |                                     |
|----------|--|-------------------------------------|
| General. | PCB terminal block                     | Rated : 1000V,41A 10mm <sup>2</sup> |
|          | Single row , 7.50mm pitch , 02-16 Pole |                                     |
|          | Wiring orientation:180°(wire-to-board) |                                     |
|          | Screwless Type                         |                                     |

认证 ( Approval ) :  

| ■ 技术参数 Technical Data                                    | UL standard   |                      |      | IEC standard   |  |        |
|--|---|----------------------|------|--|--|--------|
|  | UL应用组别(UL Application group)  | UL Application group |      |  | IEC过电压别/污染等级(IEC overvoltage category /pollution degree) |        |
| IEC过电压别/污染等级(IEC overvoltage category /pollution degree) | B   | C                    | D    | III / 3  | III / 2  | II / 2 |
| 额定电压(Rated voltage)                                      | 600V  | 600V                 | 600V | 800V   | 1000V  | 1000V  |
| 额定电流(Rated current)                                      | 36A   | 36A                  | 5A   | 41A  | 41A  | 41A    |
| 额定连接容量(Rated connection capacity)                        | 24-8 AWG Sol&Str  |                      |      | 0.2-6mm <sup>2</sup> Sol&Str , 10mm <sup>2</sup> ( Sol ) |  |        |
| 绝缘材料(Insulation Material)                                | PA66 UL94 V-0   |                      |      |  |  |        |
| 电流承载部件材料和镀层( Material & Plating of Current carrier )     | Copper alloy , Tin plated   |                      |      |  |  |        |
| 接线弹片材料(Material of Clamp spring )                        | Stainless   |                      |      |  |  |        |
| 绝缘电阻(Insulation Resistance)                              | 500MΩ or more at DC500V   |                      |      |  |  |        |
| 耐电压(1分钟)(Withstanding Voltage/1Min)                      | 2200V   |                      |      |  |  |        |
| 额定冲击电压(Rated surge voltage)                              | 8000V   |                      |      |  |  |        |
| 接线螺丝(Wire clamp unit Screw) , 最大扭矩( torque Max. )        | --  |                      |      |  |  |        |
| 固定螺丝(Mounting Screw) , 扭矩(torque)                        | --  |                      |      |  |  |        |
| 剥线长度(Wire stripping length)                              | 15mm  |                      |      |  |  |        |
| 使用温度(Operating temperature)                              | -40°C up to +115°C  |                      |      |  |  |        |
| 焊接方式(Soldering recommend)                                | Wave soldering ,260°C 5S Max (Single Wave) , 260°C 10S Max(Double Wave) |                      |      |  |  |        |

■ 订购方式(How to order)

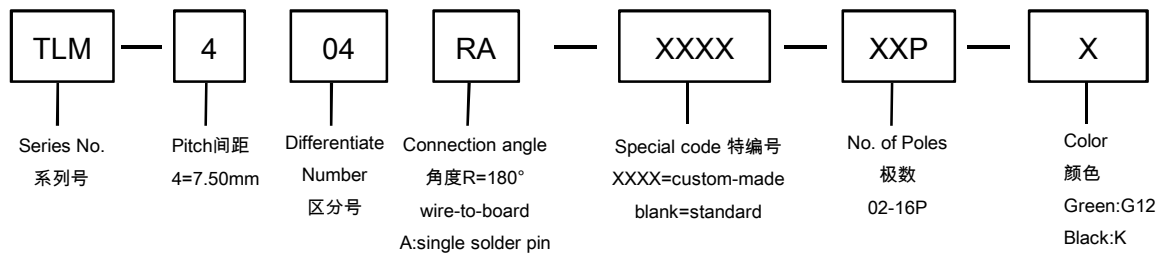

Web:www.tielee.com/www.china-tianli.com/ TEL:+86-574-6347-9600,6389-6436 Mail : sale@china-tianli.cn

地址:中国浙江省宁波杭州湾新区庵东工业园区纬三路138号

ADD : 138 , Weisan Rd.,Andong Development Zone, Hangzhou Bay Area, Ningbo, Zhejiang, China